

HDO902 CATV FIBRE TRANSMITTER

HDO902 is a high performance DFB laser transmitter for forward path (downstream) fibre optic links in CATV networks. It is installed into HDX002 installation frame. HDO902 is available on different optical output power and distortion categories to fit different performance requirements. The output power range is from +2 dBm up to +15 dBm.

Features

- Standardised input and test point levels
- Broadcast and narrowcast inputs with adjustments
- High narrowcast isolation
- Integrated driver amplifiers
- Automatic power control as standard feature
- Optional spectrum analyser function
- Fibre connectors can be located at the rear or at the front panel
- Small form factor family, 2 RU height
- Local and remote software control of all adjustments
- Forced cooling through the unit



Management features

- Monitoring of APC (Automatic Power Control) functionality with user configurable offset
- Optical output power monitoring
- Laser bias current monitoring
- TEC (Thermo-Electric Cooler) current monitoring
- Laser temperature monitoring
- Broadcast input equaliser adjustment
- Narrowcast input signal backoff adjustment
- Signal level adjustment
- LED indicators for signal and module statuses
- Internal temperature measurement and monitoring
- Intelligent fan speed control with monitoring
- Non-volatile logging of 32 latest events, including alarms, alarming values, settings changes and application starts.
- Uptime and total uptime counters
- All adjustments and alarm limits fully user configurable
- Local PC connection through backplane HDO bus with DVX012 cable
- Remote IP connection through HDC100 controller module

Technical specifications

Parameter	Specification	Note	
Optical parameters			
Light source	Cooled DFB with optical isolator		
Peak wavelength	1310 nm	1)	
Output power, nominal value	+2 dBm	2)	
	+4 dBm		
	+6 dBm		
	+8 dBm		
	+10 dBm		
	+11 dBm		
	+12 dBm		
	+13 dBm		
	+14 dBm		
	+15 dBm		
Relative intensity noise	-155 dBc/Hz	3)	
OMI per channel	4.5% for CENELEC 42 chs. loading	4)	
Number of optical outputs	1		
RF parameters			
Frequency range	47...862 MHz		
RF impedance	75 Ω		
Input return loss	18 dB	5)	
Flatness	± 0.4 dB	6)	
Automatic power control (APC)	Yes	7)	
Laser test point level for 4.5 % OMI	78 dB μ V	8)	
Broadcast branch			
Input level	77 dB μ V	9)	
Level adjustment range	10 dB		
Equaliser adjustment range	0...6 dB		
Narrowcast branch			
Narrowcast loading	20 pcs. 256-QAM signals		
Input level	Broadcast input level + 10 dB	10)	
Level adjustment range	30 dB	11)	
Narrowcast isolation	60 dB	12)	
Spectrum analyser module (optional)			
Measurement range	47...862 MHz, 0.25 MHz steps	13)	
Measurement bandwidth	1.5 MHz	14)	
Dynamic range	70...110 dB μ V	15)	
Measurement inaccuracy	± 1.5 dB	16)	
Noise and distortion performance			
<u>CENELEC, 42 un-modulated channels</u>			
Link C/N with 0 dBm to receiver	<u>Enhanced</u> 54 dB	<u>Standard</u> 54 dB	2), 17)
CTB, guaranteed value	68 dB	65 dB	18)
CSO, guaranteed value	63 dB	60 dB	18)
<u>NTSC-77, un-modulated channels</u>			
Typical link C/N with 0 dBm to receiver	<u>Enhanced</u> 54 dB	<u>Standard</u> 54 dB	2), 17)
CTB, typical value	70 dB	67 dB	19)
CSO, typical value	65 dB	62 dB	19)

CENELEC 42 ch assumes analogue loading up to 862 MHz.

NTSC-77 assumes analogue loading up to 550 MHz.

Digital channels can be placed everywhere in the frequency spectrum in both cases taking into account the loading they represent.

General

Power consumption	17 W	20)
Supply voltages	25 V / 450 (600) mA	20)
	6.3 V / 800 (1200) mA	20)
RF connectors	F female	21)
Optical connector	SC/APC, E-2000	22)
Cooling	Field replaceable fan	23)
Dimensions	2U x 7HP x 380 mm	h x w x d
	Occupies 1/12 of HDX002	
Weight	1.5 kg	
EMC compliance	EN 50083-2	24)
Enclosure classification	IP20	
Operating temperature range	0...+45 °C	
Storage temperature range	-20...+60 °C	
Operating relative humidity	0...85 %	

Notes

- 1) Typical peak wavelength at 25°C. The peak wavelength variation range between individual transmitters is ±20 nm.
- 2) The inaccuracy of the output power is given to the nominal value. 2...8 dBm transmitters have -0.5/+1.9 dB inaccuracy and 10...15 dBm transmitters have -0.5/+0.9 dB inaccuracy. The C/N values are based on the fibre length up to 10 km and the noise current density of 7 pA/√Hz. See graphs below. Longer fibres may have an impact on C/N depending on the input power of the receiver, the optical modulation index, the properties of the fibre and also the chirp characteristics of the laser. For instance the fibre of 25 km causes typically 1...1.5 dB penalty on C/N when 0 dBm is delivered to the receiver.

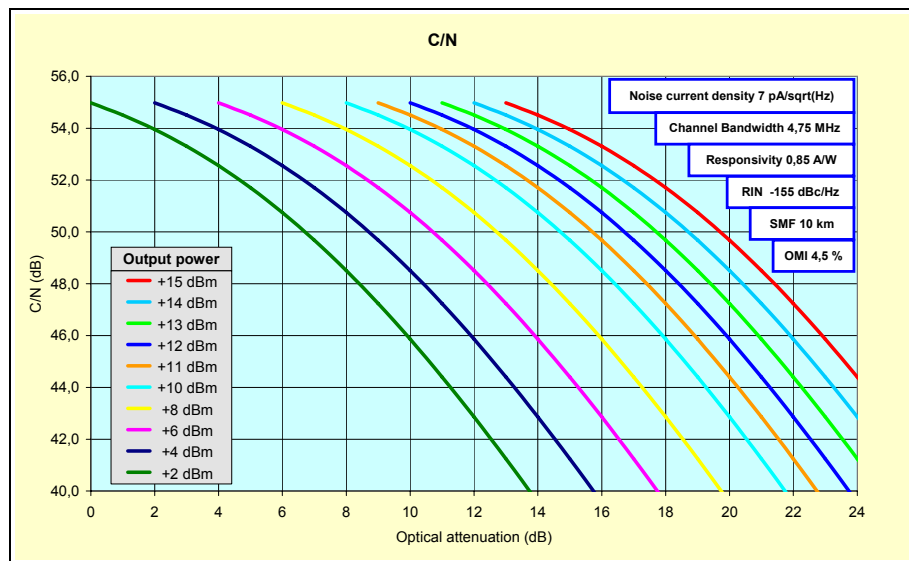

- 3) Worst case value.
- 4) Typical value. The minimum value is 4.0 %. With NTSC-77 typical OMI value is 4.0 %.
- 5) Typical value is 18 dB on the whole frequency band. The minimum value is 18 dB and above 40 MHz -1 dB/ octave.
- 6) Typical value. Maximum value is ±0.75 dB. Note that the narrowcast branch does not contain an equalizer and the narrowcast branch negative slope can be up to 1 dB.
- 7) APC is based on broadband detection in which the total laser driving power is measured and adjusted so that if the RF power is evenly divided into 42 channels the resulted OMI/channel is 4.5 %. Off-set can be set by the user.
- 8) Typical accuracy is ±0.4 dB. Maximum value is ±0.75 dB.

- 9) Input level required to reach 4.5 % OMI with adjustments in 0 dB positions.
- 10) With the narrowcast attenuator set to 0 dB position, the narrowcast input level has to be 10 dB higher than the broadcast input level to reach the same OMI in laser. (no back-off)
- 11) An additional 30 dB adjustment range compared to broadcast adjustments. The narrowcast signal back-off is adjusted with this.
- 12) Narrowcast isolation means the wanted-to-unwanted narrowcast signal level difference at the transmitter output. The unwanted signal leaks from one transmitter to another through the broadcast signal splitter
- 13) Frequencies 246.75 MHz, 266.00 MHz, 532.25 MHz, 571.00 MHz and frequencies within 0.75 MHz from these frequencies cannot be measured. If entered as measurement / pilot frequencies, the unit will use nearest allowed frequency.
- 14) Typical -3 dB bandwidth. Typical -20 dB bandwidth is 2.5 MHz.
- 15) For modulated PAL signal. For QAM detection the dynamic range is approx. 6 dB higher. Nominal level denotes 4.5 % OMI. (0.45...45 % OMI range)
- 16) This is the typical performance over band 50...740 MHz for PAL signals with -15 ... +20 dB level with respect to nominal level. For PAL signals between 740...860 MHz and all QAM signals the accuracy is ± 2.0 dB. Between -20 dB...-15 dB the accuracy is ± 2.5 dB. For unmodulated carrier the actual level is 0.6 dB higher than the measured level.
- 17) Typical value with 10 km fibre. The minimum value is 53 dB with 4.5 % OMI. With NTSC-77 the CNR values are achieved with 4.0 % OMI.
- 18) Minimum value at 25°C with CENELEC 42 channel raster. Standard performance transmitter has 1 dB lower distortion specification between 750 and 862 MHz, meaning 64 dB and 59 dB. With modulated channels the distortion distances are better, CTB typically 8 dB, CSO 6 dB.
- 19) With modulated channels the distortion distances are better, CTB typically 8 dB, CSO 6 dB.
- 20) Typical power consumption at 25°C. Highest power transmitters with spectrum analyser in extreme conditions can consume 22.5 W, absolute maximum current values in parenthesis.
- 21) Fixed connections are located at the rear panel. Test points are located at the front panel.
- 22) Fibre connectors can be located at the rear or at the front panel.
- 23) The fan can be replaced by the user without signal interruption.
- 24) Radiation limit 20 dBpW.

Block diagram

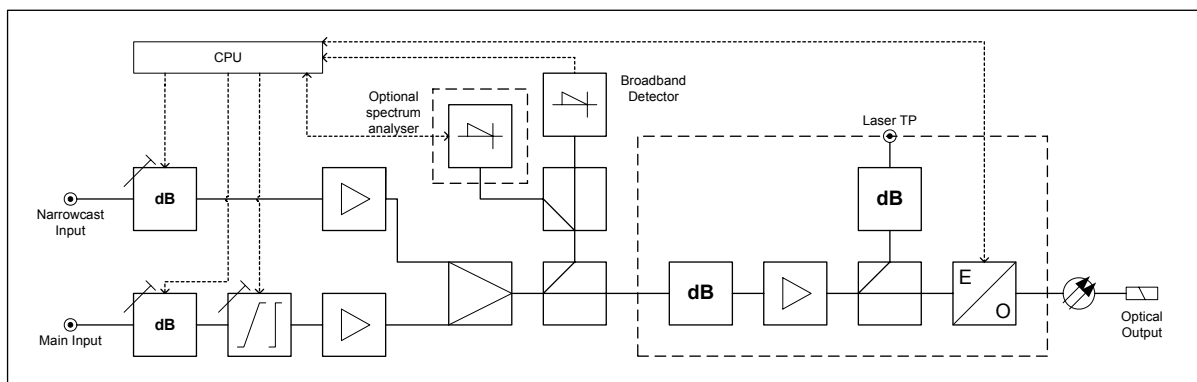

Ordering information

		1-		2-	3-
	1	3	1	2	1
HDO902	A		-	-	

1-1 Transmitter performance	
A	Enhanced performance
B	Standard performance
1-3 Output power	
02	+2 dBm
04	+4 dBm
06	+6 dBm
08	+8 dBm
10	+10 dBm
11	+11 dBm
12	+12 dBm
13	+13 dBm
14	+14 dBm
15	+15 dBm
2-1 Fibre location	
F	Front panel
R	Rear panel
2-2 Fibre connector type	
C	E-2000
D	SC/APC, 8 deg.
H	SC/APC with shutter, 8 deg.
3-1 Signal monitoring	
A	Spectrum analyser. Not available yet.
X	None