

CXE880 FIBRE OPTIC NODE



The CXE880 is a fibre deep optical node. It is designed for cases where high performance and cost effectiveness are a demand.

Requirements of future networks, like 1 GHz frequency band and 85/108 MHz return split are taken in account.

Alignment of this product is made easy and no external plugs are needed. Fibre connectors are situated at the housing wall, enabling quick installation.

OLC as well as gain and slope adjustments use electrical controls that improve the reliability of the node.

Optional cost effective status monitoring card makes this node reliable and raises the performance level of fibre network.

Features

- 1000 MHz downstream
- 85 MHz upstream
- Simple adjustment without signal interruptions
- OLC
- Optional remote monitoring of key parameters
- Wide range of upstream laser technologies available
- Low noise current density
- GaAs MESFET output amplifier
- OMI test point
- No output plug-in needed in normal operation
- LED indication for optical level and laser bias
- Optical level measurement
- Excellent surge and ESD protection

Technical specifications

Parameter	Specification	Note
Downstream signal path		
Light wavelength	1290...1600 nm	
Optical input power range	-7...0 dBm	1)
Frequency range	47...1000 MHz	2)
Return loss	18 dB	3)
OLC limited output level	111 dB μ V	4)
Gain limited output level (without OLC)	118 dB μ V	5)
Level adjustment	0...-15 dB	6)
Interstage slope	0 / 8 dB	7)
Flatness	\pm 0.5 dB	8)
Test point	-20 dB	8)
Noise current density	6 pA / \sqrt Hz	10)
CTB 42 channels	112 dB μ V	11)
CSO 42 channels	112 dB μ V	11)
XMOD 42 channels	109 dB μ V	11)
Upstream signal path		
Frequency range	5...85 MHz	2)
Return loss	18 dB	
Input level	65.0 dB μ V	12)
Input level control	0...-31 dB	13)
Injection point	-20 dB	14)
Optical output power	+ 3 dBm	15)
OMI test point	-10 dB	
General		
Power consumption	16 W	16)
Supply voltages	26...65 VAC / \pm 30...90 VDC 165...255 VAC	
Supply current	see note	17)
Maximum current feed through	2.0 A / port	
Hum modulation	70 dB	18)
Optical connectors	SC/APC	
Output connectors	F- f / IEC-f / PG11 / 5/8" / 3.5/12	
Test point connectors	F- female	
Dimensions	182 (210) x 140 (148) x 84 mm	
Weight	1.6 kg	
Enclosure classification	IP43	
Operating temperature range	-40...+55 °C	
EMC compatibility	EN 50083-2 (IEC 60728-2)	
Safety	EN 60728-11	
ESD	4 kV	19)
Surge	6 kV	20)

Notes

- 1) OLC is operational within this input power range.
- 2) Forward / return frequency split can be selected with plug-in duplex filter.
- 3) The limiting curve is defined at 40 MHz -1.5 dB / octave.
- 4) This is the maximum output level with OLC when OMI is 4.0 %. The level is available with the optical input power of -7...0 dBm. The used wavelength is 1310 nm.
- 5) This level is available with optical input level of - 3 dBm (OLC off and OMI 4%).
- 6) Step size is 1 dB.
- 7) Between 47...1000 MHz. Slope can be selected with jumper. There is no signal interruption during selection.
- 8) Typical value.
- 9) TP is from a directional coupler and has a ± 0.8 dB tolerance.
- 10) This is a typical value at 862 MHz when the optical input power is -7 dBm. The value can be used for C/N calculations.

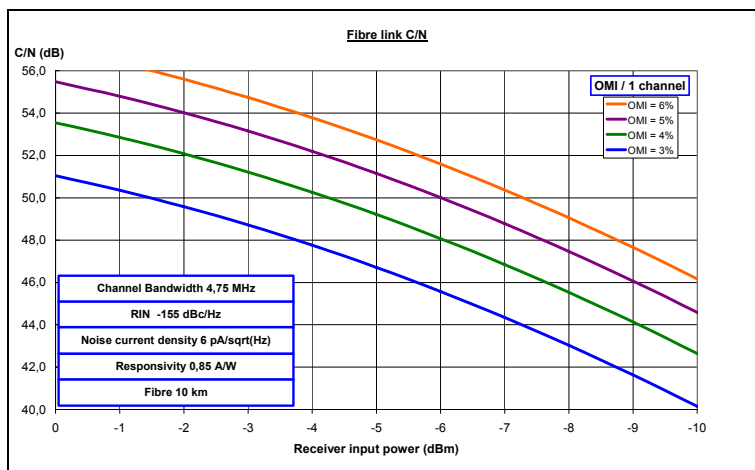

- 11) EN50083-3. Optical input power is -4 dBm and OMI is 4.0 %. The output is 8 dB cable equivalent sloped. All results are typical values in room temperature, which can be used in system calculations. XMOD is measured at the lowest channel. The recommended maximum output level is 114 dB μ V with 21 channels and sloped output.
- 12) 10 % OMI can be reached with this input level if the input attenuator is having 0 dB value.
- 13) Rotary switch has control range of 0...-15 dB. Additional -16 dB can be set with separate electrically controlled attenuator.
- 14) Forward path test point can be used as an injection point for return path test signal.
- 15) Output power for FP laser is +1 dBm. CWDM lasers are using +3 dBm.
- 16) Without monitoring module. With monitoring the value is 0.5 W higher.

17) The curve presents the current need without monitoring card.

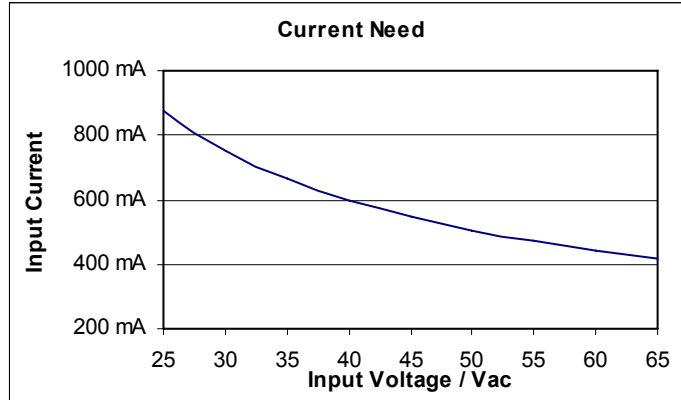

18) 70 dB hum value is valid at any frequency from 10 to 862 MHz, when the remote current is less than 2.0 A/ port. 3.0 A is the maximum current, which can be locally injected into both ports together.

19) EN61000-4-2, contact discharge to enclosure and RF ports.

20) EN61000-4-5, 1.2 / 50 μs pulse to RF ports.

Block diagram

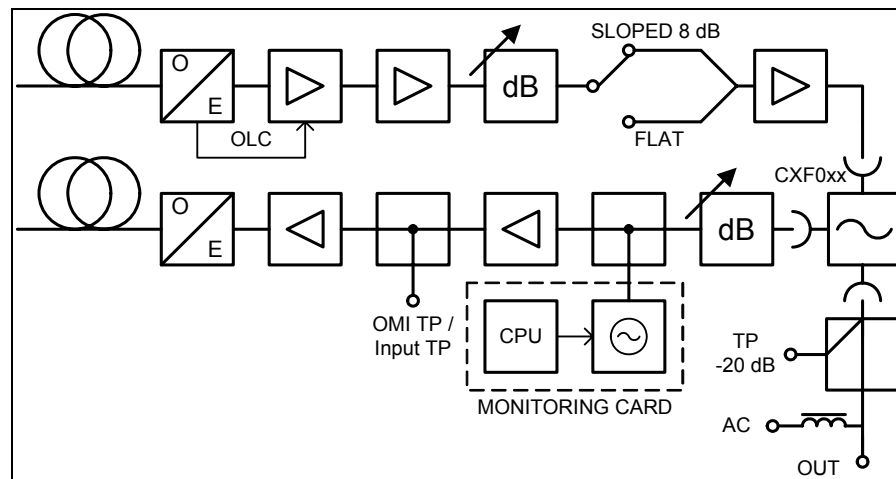

Monitoring card

CXE880 key parameters can be monitored with optional factory installed monitoring card. Up to 16 CXE880 return path signals can be combined and received with a single HDO203 data receiver.

The monitoring card transmits status information using 10.7 MHz data link. Data is transmitted in bursts with 38400 bps speed and FSK modulation with +/-67 kHz deviation. Transmit level is equivalent to 60 dB μ V at return path input when return path gain is set to maximum. Resulting channel bandwidth is 400 kHz with <-50 dBc typical spurious tones outside channel.

Parameters transmitted by CXE880 monitoring card:

- Identification information: HW, SW, serial #, return transmitter wavelength
- Optical input power with high and low alarm
- Laser bias current with high and low alarm
- Internal temperature with high and critical alarm and LED
- Local supply voltage with alarm and LED
- Remote AC supply voltage
- Lid open alarm from integrated light sensor
- Power failure statistics: uptime, total uptime, reset count with alarm
- Internal diagnostics with alarm and LED

Ordering information

CXE880 configuration map
 DOC0015375
 Rev 002

	1-	2-	3-	4-	4-	5-	5-	6-	7-
	1	2	1	1	3	1	2	1	1
CXE880		-	-						

1-1 Platform type
A High gain
1-2 Power supply
A Local powering, euro plug (230 VAC)
B Remote powering with cable clamp (65 VAC)
C Local powering, UK plug (230 VAC)

2-1 Output connection
A PG11
B 5/8"
C IEC
D 3.5/12
E F

3-1 Diplexer filter
A 30/47 MHz
B 42/54 MHz
C 50/70 MHz
D 65/85 MHz
E 65/85 MHz (18 MHz HP filter)
X None

4-1 Return path transmitter
40 FP 1310 nm
47 CWDM 1470 nm
49 CWDM 1490 nm
51 CWDM 1510 nm
53 CWDM 1530 nm
55 CWDM 1550 nm
57 CWDM 1570 nm
59 CWDM 1590 nm
61 CWDM 1610 nm

4-3 Optical connector for TX and RX
D SC/APC, 8 deg (2 pcs)
X None

5-1 Optical filter
0 FWDM filter, 1310/1550 nm (AC6570)
2 FWDM filter, 1310nm/CWDM (AC6572)
X None

5-2 Optical connector for filter
D SC/APC, 8 deg (1 pcs)
X None

6-1 Status monitoring
A Installed
X None

7-1 Reserved for future
X None