

AC800 FIBRE OPTIC NODE



The AC800 is a single active output node. It is based on fixed receiver concept but new features can be added by flexible modular solutions. The platform is already designed to be future proof. New automatic functions can be added later in the form of SW or plug-in module. There can be ALS operation controlled by EMT unit or by a cost effective detector module with fixed pilot frequencies. The transponder can be installed easily into plug-in slot without external cabling. This module does the measurements and controls the ingress switches on the mother board. It can be operated locally by lap top or hand terminal or remotely through EMS.

The amplifier stages are based on high performance GaAs-circuits, what ensures the highest possible signal quality. Inter-stage gain can be controlled in two positions, which means wide operational dynamic range. By using internal splitting there can be available 2 separate outputs with high current passing. Return signal can be fed directly into TX through external injection port.

Features

- Wide range of upstream laser technologies available
- Optical parameters monitored
- Optimised fibre organiser
- Amplifiers stages use GaAs technology
- 2 outputs
- AGC functions
- Signal level measurement
- Efficient surge and ESD protection
- External return injection or output connection
- Plug-in module adjustments
- Return path ingress switch built-in
- HMS compatible EMT module available
- Fixed station memory for electrical identification

Technical specifications

Parameter	Specification	Note
Downstream signal path		
Light wavelength	1290...1600 nm	1
Optical input power range	- 5...+ 1dBm	2
Frequency range	47 / 54 / 70 / 85...862 MHz	
Return loss	20 dB	3
Gain limited output level	110 dBuV	4
Gain adjustment	18 dB	5
Mid-stage slope	8 dB	6
Flatness	± 0.4 dB	7
Test point	- 20 dB	8
Transponder connection	- 19 dB	9
Noise current density	7 pA / √ Hz	10
CTB 42 channels	113.0 dBμV	11
CSO 42 channels	115.0 dBμV	11
XMOD 42 channels	111.0 dBμV	11
CTB 110 / 77 channels	71.0 / 77.0 dBc	12
CSO 110 / 77 channels	61.0 / 73.0 dBc	12
XMOD 110 / 77 channels	65.0 / 71.0 dBc	12
Upstream signal path		
Frequency range	5...30 / 42 / 50 / 65 MHz	
Return loss	20 dB	
Ingress switching	0 / - 6 / < - 45 dB	
Input level	62.0 dBμV	13
Test point	- 20 dB	14
Transponder connection	- 26 dB	15
General		
Power consumption	24 W	16
Supply voltage	27...65 Vac , ±33...90Vdc / 205...255 Vac	
Supply current	see note	17
Maximum current feed through	8.0 A / port	18
Hum modulation	70 dB	18
Optical connectors	SC/APC, FC/APC, E-2000	19
Output connectors	PG11	
Test point connectors	F- female	
Dimensions	245 x 255 x 100 mm	h x w x d
Weight	3.0 kg	
Operating temperature	-40...+55 °C	
Class of enclosure	IP 54	
EMC	EN50083-2	
ESD	4 kV	20
Surge	6 kV	21

Notes

- 1) The typical responsivity of the photodiode is 0.85 A/W at 1310 nm and 0.95 A/W at 1550 nm.
- 2) Typical operation range.
- 3) The limiting curve is defined at 40 MHz -1.5 dB / octave.
- 4) This is the guaranteed maximum output level when OMI is 4.0% . The level is available with the optical input power of - 5 dBm. The used wavelength is 1310 nm. Typical output level in this condition is 111.0 dBuV.
- 5) The gain be adjusted at 2 mid-stage plug-in positions depending on optical input level and required RF output power. Fixed value JDA9xx series attenuators are available with the steps of 1 dB.
- 6) The platform is defined with 8 dB tilted output. However, it is possible to use the node with other slopes by changing the mid-stage equaliser plug.
- 7) Typical value. The guaranteed value is ± 0.75 dB. Flatness is defined with mid-stage equaliser and diplex filter. All other used plug modules are 0 dB jumpers.
- 8) Output TP is from a directional coupler and has a ± 0.75 dB tolerance. The output test point can be used as an injection point for return path test signal.
- 9) This is the level difference between output and transponder connection pin on the motherboard.
- 10) This is a typical value at 862 MHz and the value can be used for C/N calculations.

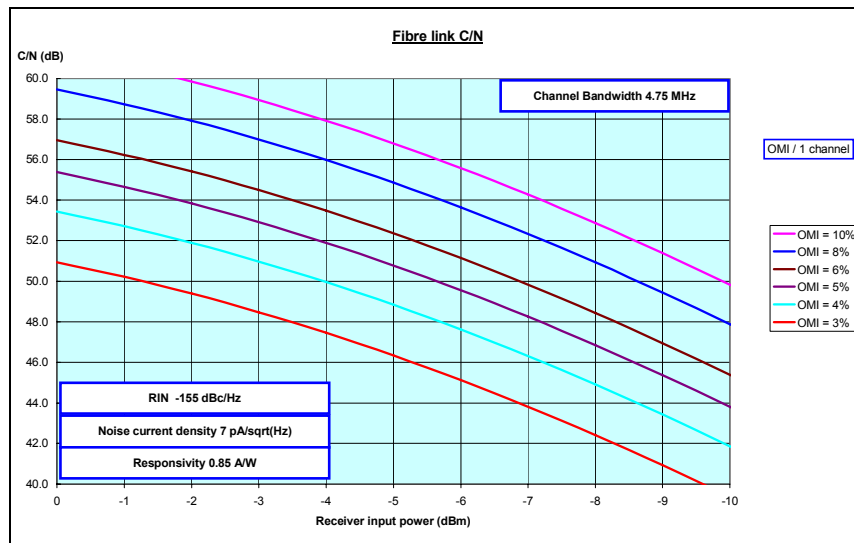

- 11) EN50083-3. Optical input power is -5 dBm and the OMI is 4.0%. The output was 8 dB cable equivalent sloped. All results are typical values in room temperature, which can be used in system calculations. XMOD is measured at the lowest channel. The highest recommended output level for the node is 112.0 dBuV with 42 channels.
- 12) Measured with 77 and 110 NTSC channels. The output was 12 dB linearly sloped and the used levels were at 55 / 550 / 750 / 862 MHz 35.0 / 42.5 / 45.5 / 47.0 dBmV. All results are typical values in room temperature, which can be used in system calculations. XMOD is measured at 55.25 MHz. The high end of the frequency band up to 862 MHz was fulfilled with QAM channels having a level of -6 dB relative to analogue CW carriers. The highest recommended output level for the node is 50 dBmV with 110 channels and 52 dBmV with 77 channels.
- 13) Typical input level for 4% OMI. Defined at the output connector of the node. Valid with AC6840 transmitter.
- 14) Return TP is using a bi-directional transformer and has a ± 1.5 dB tolerance.

- 15) This is the theoretical level difference between the input connector of the return signal path and the injection pin of the up-stream signal of the transponder. It can be used when adjusting the transmitter of the modem.
- 16) An optical transmitter (AC6840) is installed. With EMT module (AC6910) the power dissipation is 2 W higher.
- 17)

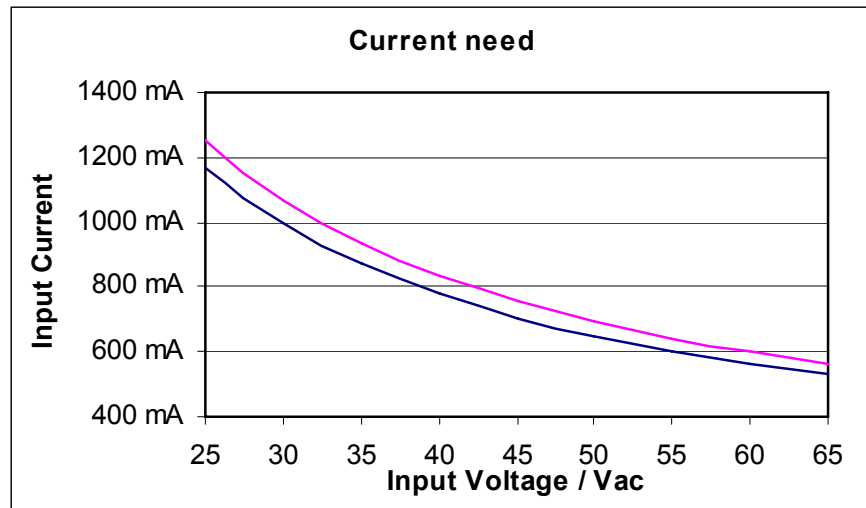

The lower curve is with AC6840. The higher includes also the EMT module.

- 18) At any frequency from 10 to 862 MHz when the remote current is less than 8 A. The hum modulation is defined to be $20 \lg(2U/U_{pp})$, where 2U is the peak-to-peak value of the carrier and U_{pp} the peak-to-peak value of the modulation signal (50 and 100 Hz). 12 A is the maximum current, which can be locally injected into all ports together.
- 19) The type has to be specified by customer. See available options in "Ordering Information".
- 20) EN61000-4-2, contact discharge to enclosure and RF-ports.
- 21) EN61000-4-5, 1.2 / 50 μ s pulse to RF-ports.

Monitored Functions and Controlled Parameters

- Optical level of the RX module
- Laser current measurement
- Pilot generator control in optical TX
- RF amplifier ON/OFF in optical TX
- Return path ingress switches ON/ -6 dB / OFF control
- 65 VAC voltage measurement
- Local voltage 12 V
- Local voltage 24 V
- Temperature measurement
- Individual channel level and spectrum measurement (AC6951)
- AGC function
- Lid status monitoring
- Local connection indication at server
- Configuration data stored in main board eeprom (station memory)

Block Diagram

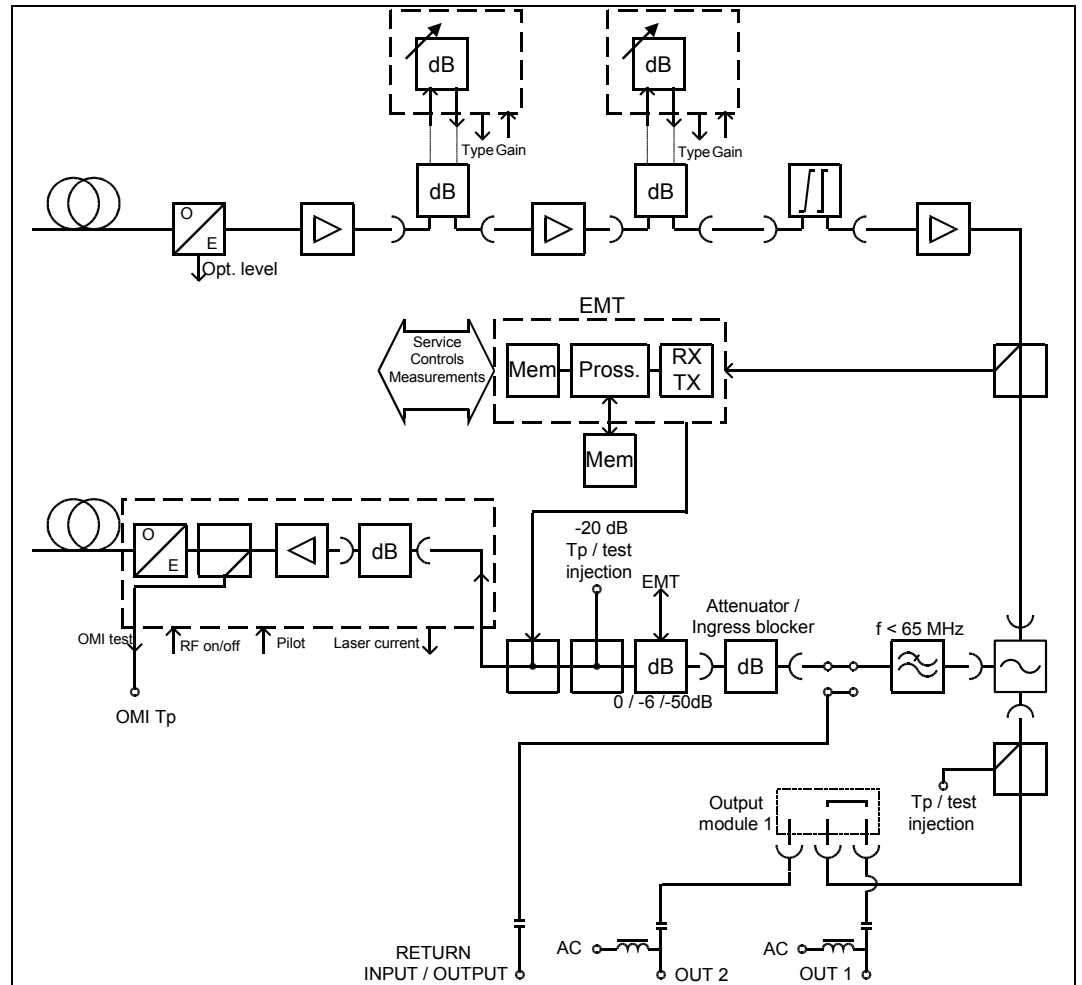

Ordering Information

AC800 configuration map

1-		2-		3-		4-		5-		6-			
1	2	3	4	5	1	2	3	4	5	1	2		
AC800													
<table border="1"> <tr> <td style="width: 50%; vertical-align: top;"> <p>1-1 Fibre feed-through adapter C 1-4 fibres (KDO900) E 5/8 Adapter (KDC316) X None</p> <p>1-2 Additional return input connection A PG11 B 5/8 C IEC D 3.5/12 E F X None (PG11 sealing plug)</p> <p>1-3 Output 2 connection A PG11 B 5/8 C IEC D 3.5/12 E F X None (PG11 sealing plug)</p> <p>1-4 Output 1 connection (first from right) A PG11 B 5/8 C IEC D 3.5/12 E F</p> <p>1-5 Optical connector for receiver RX1 A SC/APC, 9 deg. B FC/APC, 8 deg. C E-2000 D SC/APC, 8 deg. E SC/APC, 8 deg. AMP</p> <p>2-1 Level pre-adjustment A 0 dB (JDA900) B Electrical level adjustment (AC6173) X None</p> <p>2-2 Interstage slope and level adjustment A 8 dB slope @ 862 MHz (TDE810) and no level adjustment plug B 8 dB slope @ 862 MHz (TDE810) and max. output level (JDA900) C 8 dB slope @ 862 MHz, temp. comp. (TTE810) and no level adjustment plug D Flat response (TXA000) and max. output level (JDA900) G 8 dB slope @ 862 MHz (TDE810) and electrical level adjustment (AC6173) X None</p> <p>2-3 Diplexer filter A 30/47 MHz (CXF030) B 42/54 MHz (CXF042) C 50/70 MHz (CXF050) D 65/85 MHz (CXF065) E Forward path jumper (CXF000) F 55/70 MHz (CXF055) X None</p> <p>2-4 Output module A 0 dB, 1 output in use (AC6120) B Splitter -3.7 dB, 2 outputs in use (AC6124) C Tap -8 dB, 2 outputs in use (AC6128) D Tap -12 dB, 2 outputs in use (AC6112) E Tap -16 dB, 2 outputs in use (AC6116) F Tap -20 dB, 2 outputs in use (AC6119) X None</p> <p>2-5 Return path input module A 0 dB plug (JDA900) B HPF 15 MHz, ingress blocker (AC6223) X None</p> </td> <td style="width: 50%; vertical-align: top;"> <p>3-1 Return path transmitter TX1 30 FP 1310 nm (AC6830) 35 FP 1310 nm (AC6835) 40 FP 1310 nm (AC6840) 45 DFB 1310 nm (AC6845) 47 CWDM 1470 nm (AC6847) 49 CWDM 1490 nm (AC6849) 51 CWDM 1510 nm (AC6851) 53 CWDM 1530 nm (AC6853) 55 CWDM 1550 nm (AC6855) 57 CWDM 1570 nm (AC6857) 59 CWDM 1590 nm (AC6859) 61 CWDM 1610 nm (AC6861) XX None</p> <p>3-3 Optical connector for transmitter TX1 A SC/APC, 9 deg. B FC/APC, 8 deg. C E-2000 D SC/APC, 8 deg. E SC/APC, 8 deg. AMP X None</p> <p>4-1 Optical filter 1 0 FWD filter, 1310/1550 nm (AC6570) X None</p> <p>4-2 Optical connectors (3 pcs) for filter 1 A SC/APC, 9 deg. B FC/APC, 8 deg. C E-2000 D SC/APC, 8 deg. E SC/APC, 8 deg. AMP X None</p> <p>5-1 Element management transponder A Standard, CATVisor (AC6910) B With tuner level measurement, CATVisor (AC6950) C Standard, HMS (AC6910 HMS) D With tuner level measurement, HMS (AC6950 HMS) E ALC controller (AC6940) G Standard, CATVisor (AC6951) H Standard, HMS (AC6951 HMS), Q2/2007 X None</p> <p>6-1 Power supply A Local powering, euro plug (230 VAC) B Remote powering with cable clamp (65 VAC) C Local powering, UK plug (230 VAC)</p> <p>6-2 Platform performance A High gain, socket head screws</p> </td> </tr> </table>												<p>1-1 Fibre feed-through adapter C 1-4 fibres (KDO900) E 5/8 Adapter (KDC316) X None</p> <p>1-2 Additional return input connection A PG11 B 5/8 C IEC D 3.5/12 E F X None (PG11 sealing plug)</p> <p>1-3 Output 2 connection A PG11 B 5/8 C IEC D 3.5/12 E F X None (PG11 sealing plug)</p> <p>1-4 Output 1 connection (first from right) A PG11 B 5/8 C IEC D 3.5/12 E F</p> <p>1-5 Optical connector for receiver RX1 A SC/APC, 9 deg. B FC/APC, 8 deg. C E-2000 D SC/APC, 8 deg. E SC/APC, 8 deg. AMP</p> <p>2-1 Level pre-adjustment A 0 dB (JDA900) B Electrical level adjustment (AC6173) X None</p> <p>2-2 Interstage slope and level adjustment A 8 dB slope @ 862 MHz (TDE810) and no level adjustment plug B 8 dB slope @ 862 MHz (TDE810) and max. output level (JDA900) C 8 dB slope @ 862 MHz, temp. comp. (TTE810) and no level adjustment plug D Flat response (TXA000) and max. output level (JDA900) G 8 dB slope @ 862 MHz (TDE810) and electrical level adjustment (AC6173) X None</p> <p>2-3 Diplexer filter A 30/47 MHz (CXF030) B 42/54 MHz (CXF042) C 50/70 MHz (CXF050) D 65/85 MHz (CXF065) E Forward path jumper (CXF000) F 55/70 MHz (CXF055) X None</p> <p>2-4 Output module A 0 dB, 1 output in use (AC6120) B Splitter -3.7 dB, 2 outputs in use (AC6124) C Tap -8 dB, 2 outputs in use (AC6128) D Tap -12 dB, 2 outputs in use (AC6112) E Tap -16 dB, 2 outputs in use (AC6116) F Tap -20 dB, 2 outputs in use (AC6119) X None</p> <p>2-5 Return path input module A 0 dB plug (JDA900) B HPF 15 MHz, ingress blocker (AC6223) X None</p>	<p>3-1 Return path transmitter TX1 30 FP 1310 nm (AC6830) 35 FP 1310 nm (AC6835) 40 FP 1310 nm (AC6840) 45 DFB 1310 nm (AC6845) 47 CWDM 1470 nm (AC6847) 49 CWDM 1490 nm (AC6849) 51 CWDM 1510 nm (AC6851) 53 CWDM 1530 nm (AC6853) 55 CWDM 1550 nm (AC6855) 57 CWDM 1570 nm (AC6857) 59 CWDM 1590 nm (AC6859) 61 CWDM 1610 nm (AC6861) XX None</p> <p>3-3 Optical connector for transmitter TX1 A SC/APC, 9 deg. B FC/APC, 8 deg. C E-2000 D SC/APC, 8 deg. E SC/APC, 8 deg. AMP X None</p> <p>4-1 Optical filter 1 0 FWD filter, 1310/1550 nm (AC6570) X None</p> <p>4-2 Optical connectors (3 pcs) for filter 1 A SC/APC, 9 deg. B FC/APC, 8 deg. C E-2000 D SC/APC, 8 deg. E SC/APC, 8 deg. AMP X None</p> <p>5-1 Element management transponder A Standard, CATVisor (AC6910) B With tuner level measurement, CATVisor (AC6950) C Standard, HMS (AC6910 HMS) D With tuner level measurement, HMS (AC6950 HMS) E ALC controller (AC6940) G Standard, CATVisor (AC6951) H Standard, HMS (AC6951 HMS), Q2/2007 X None</p> <p>6-1 Power supply A Local powering, euro plug (230 VAC) B Remote powering with cable clamp (65 VAC) C Local powering, UK plug (230 VAC)</p> <p>6-2 Platform performance A High gain, socket head screws</p>
<p>1-1 Fibre feed-through adapter C 1-4 fibres (KDO900) E 5/8 Adapter (KDC316) X None</p> <p>1-2 Additional return input connection A PG11 B 5/8 C IEC D 3.5/12 E F X None (PG11 sealing plug)</p> <p>1-3 Output 2 connection A PG11 B 5/8 C IEC D 3.5/12 E F X None (PG11 sealing plug)</p> <p>1-4 Output 1 connection (first from right) A PG11 B 5/8 C IEC D 3.5/12 E F</p> <p>1-5 Optical connector for receiver RX1 A SC/APC, 9 deg. B FC/APC, 8 deg. C E-2000 D SC/APC, 8 deg. E SC/APC, 8 deg. AMP</p> <p>2-1 Level pre-adjustment A 0 dB (JDA900) B Electrical level adjustment (AC6173) X None</p> <p>2-2 Interstage slope and level adjustment A 8 dB slope @ 862 MHz (TDE810) and no level adjustment plug B 8 dB slope @ 862 MHz (TDE810) and max. output level (JDA900) C 8 dB slope @ 862 MHz, temp. comp. (TTE810) and no level adjustment plug D Flat response (TXA000) and max. output level (JDA900) G 8 dB slope @ 862 MHz (TDE810) and electrical level adjustment (AC6173) X None</p> <p>2-3 Diplexer filter A 30/47 MHz (CXF030) B 42/54 MHz (CXF042) C 50/70 MHz (CXF050) D 65/85 MHz (CXF065) E Forward path jumper (CXF000) F 55/70 MHz (CXF055) X None</p> <p>2-4 Output module A 0 dB, 1 output in use (AC6120) B Splitter -3.7 dB, 2 outputs in use (AC6124) C Tap -8 dB, 2 outputs in use (AC6128) D Tap -12 dB, 2 outputs in use (AC6112) E Tap -16 dB, 2 outputs in use (AC6116) F Tap -20 dB, 2 outputs in use (AC6119) X None</p> <p>2-5 Return path input module A 0 dB plug (JDA900) B HPF 15 MHz, ingress blocker (AC6223) X None</p>	<p>3-1 Return path transmitter TX1 30 FP 1310 nm (AC6830) 35 FP 1310 nm (AC6835) 40 FP 1310 nm (AC6840) 45 DFB 1310 nm (AC6845) 47 CWDM 1470 nm (AC6847) 49 CWDM 1490 nm (AC6849) 51 CWDM 1510 nm (AC6851) 53 CWDM 1530 nm (AC6853) 55 CWDM 1550 nm (AC6855) 57 CWDM 1570 nm (AC6857) 59 CWDM 1590 nm (AC6859) 61 CWDM 1610 nm (AC6861) XX None</p> <p>3-3 Optical connector for transmitter TX1 A SC/APC, 9 deg. B FC/APC, 8 deg. C E-2000 D SC/APC, 8 deg. E SC/APC, 8 deg. AMP X None</p> <p>4-1 Optical filter 1 0 FWD filter, 1310/1550 nm (AC6570) X None</p> <p>4-2 Optical connectors (3 pcs) for filter 1 A SC/APC, 9 deg. B FC/APC, 8 deg. C E-2000 D SC/APC, 8 deg. E SC/APC, 8 deg. AMP X None</p> <p>5-1 Element management transponder A Standard, CATVisor (AC6910) B With tuner level measurement, CATVisor (AC6950) C Standard, HMS (AC6910 HMS) D With tuner level measurement, HMS (AC6950 HMS) E ALC controller (AC6940) G Standard, CATVisor (AC6951) H Standard, HMS (AC6951 HMS), Q2/2007 X None</p> <p>6-1 Power supply A Local powering, euro plug (230 VAC) B Remote powering with cable clamp (65 VAC) C Local powering, UK plug (230 VAC)</p> <p>6-2 Platform performance A High gain, socket head screws</p>												